

2M



AUTOMATION LTD

Microgap

Positioning System

Project Brief

The Coating and Laminating Industry has welcomed many advances in the coating process. These advances constantly place demands on technology suppliers and System Integrators alike to produce systems that are:

With the determination to uphold Autotypes primary focus of implementing exceptional standards of precision coating for films, 2M Automation

Ltd and partners Converttech Machinery Ltd came on board to assist Autotype in maintaining their lead in the industry.

Key 2M Services Supplied:

- Data Communications Software Protocol
- PID Software Development
- AC Vector Drive Parameterization
- Reliable
- Stable
- Consistent
- Accurate &
- Repeatable

Autotype International Ltd is a global company delivering market focused technical innovation for specialist printing applications. Their mission is to apply technology to help their customers in the electronics, display screen and printing industries to succeed within a fiercely competitive field.

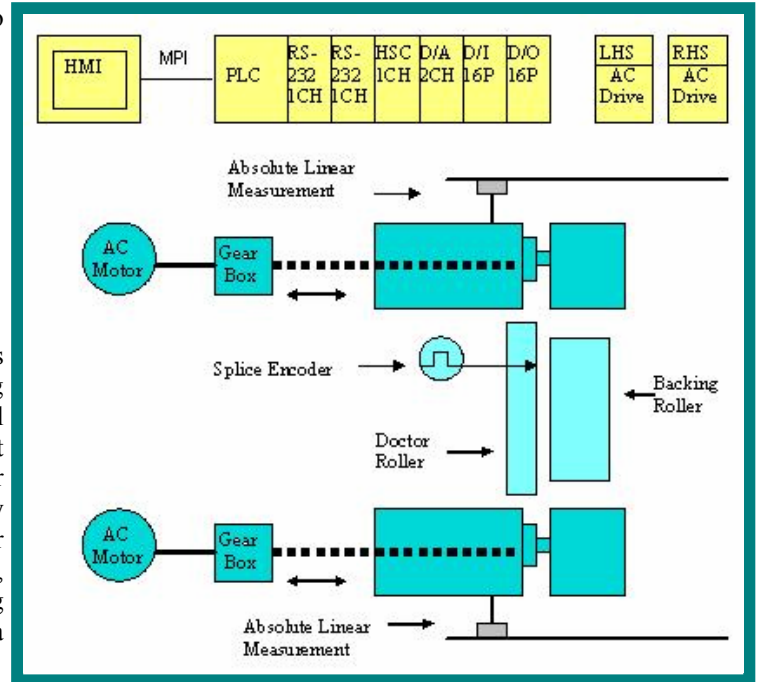

Key Components Used:

- Siemens S7-300 PLC
- Eurotherm 690 AC Vector Drives
- Siemens TP270 10" Touch Screen
- Variohm TS25 Position Transducer with RS232 Amplifier

The Microgap Positioning System was used to apply a controlled thin layer of coating to our client's film products with a resolution of 1µm (micro metre) on a Coating line.

The coating machine used was designed to give an accuracy and repeatability of 1µm. We decided to use a system that would record accurate feedback of the gap between Doctor Roller and Backing Roller positions. We had to maintain the required gap whilst the machine was running. Due to the use of accurate position measurement

Design Philosophy

equipment, we could use a normal AC Vector Closed Inverter with normal PID control in a standard PLC to

apply an efficient and cost-effective solution to a design that would otherwise have required complicated servo-controlled positioning systems.

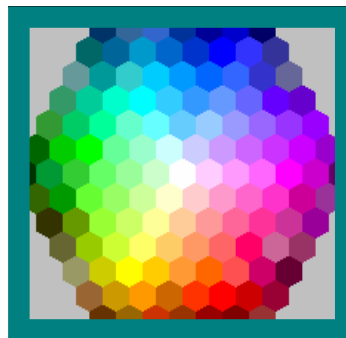

achieve the above result.

Consequently, we were able to

Proposed was a Siemens S7-300 PLC with digital and analogue input and outputs for controlling the inverters and other actuators on the machine. The absolute position measurement was achieved through analogue to serial devices. We therefore had to implement Serial Communications Modules to accept the position of the rollers.

System Overview

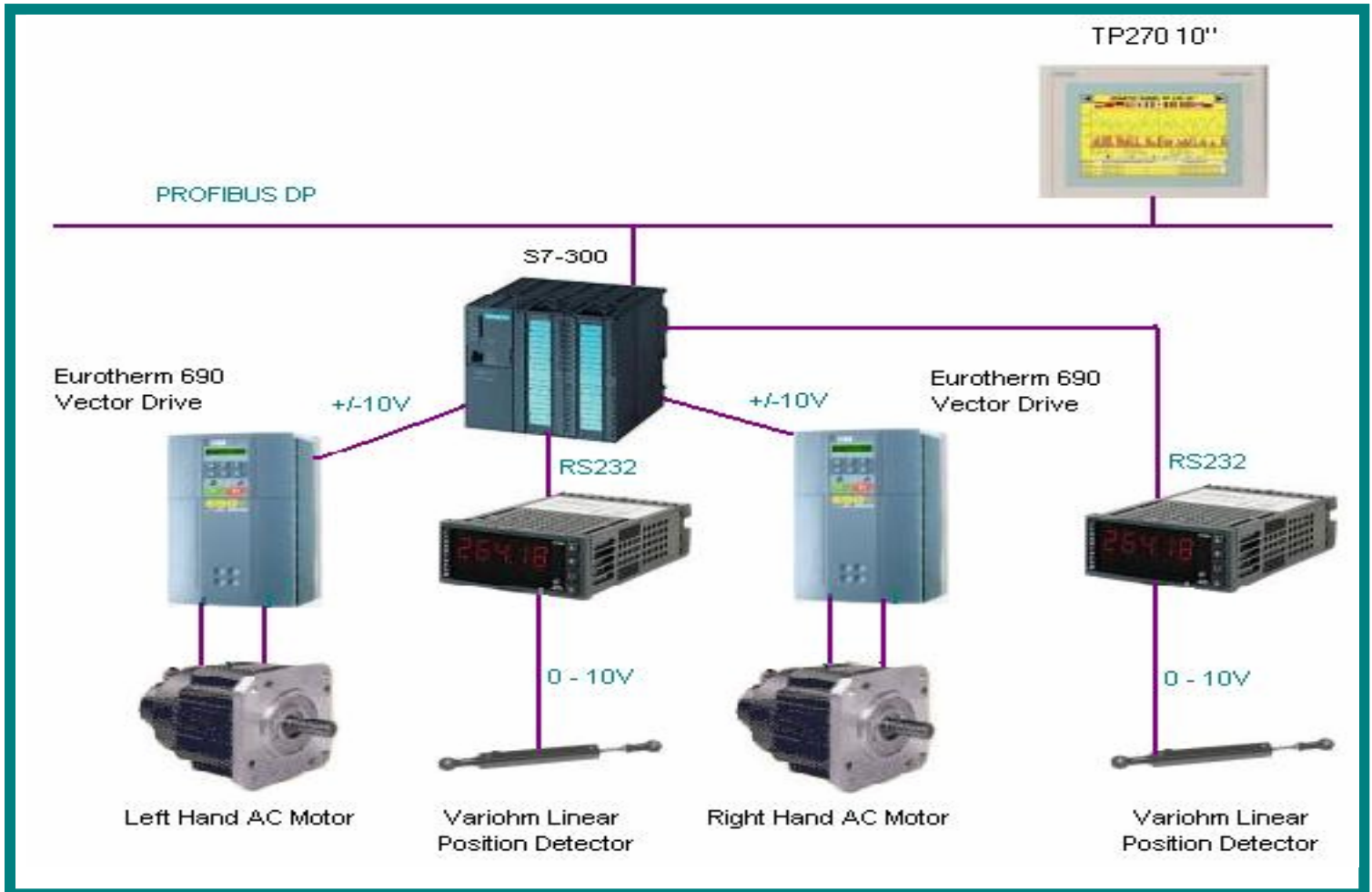

Technical Risk Management

Accurate Positioning

- Accurate positional control can be easily achieved using closed loop servo systems. However, the cost of these systems tends to be relatively high in comparison to other technologies.
- The Microgap System uses accurate position measurement and a relatively simple position control compared to the servo system. Achieving positional accuracy using a closed loop vector was only possible if the correct PID parameters were applied. It was this aspect of the project that required 2M to challenge the basic principles of closed loop control theories.
- We applied these principles and achieved the required accuracy at a fraction of the cost of a complete closed loop servo system.

Our Mission Statement

"To deliver cutting-edge, efficient, effective, customer-focused automation solutions in full and on time by working with the customer."

Safety Concerns

- Of utmost importance in this application was the capability to maintain throughout the running of the machine the gap between Doctor Roller and Backing Roller positions. This is due to the fact that after the coating process the material proceeds to pass through a dryer producing highly inflammable vapours in the process.
 - If the coating thickness were to exceed its safety limit, an explosion would result. As there was no thickness measurement between the coating station and the dryer, it was critical that the specified gap be maintained accurately.
 - A safety mechanism was therefore implemented that will shut down the system when and if the safety margins are breached.